

Stress Concentrations

The problems for Section 2.10 are to be solved by considering the stress-concentration factors and assuming linearly elastic behavior.

Problem 2.10-1 The flat bars shown in parts (a) and (b) of the figure are subjected to tensile forces $P = 3.0$ k. Each bar has thickness $t = 0.25$ in.

- For the bar with a circular hole, determine the maximum stresses for hole diameters $d = 1$ in. and $d = 2$ in. if the width $b = 6.0$ in.
- For the stepped bar with shoulder fillets, determine the maximum stresses for fillet radii $R = 0.25$ in. and $R = 0.5$ in. if the bar widths are $b = 4.0$ in. and $c = 2.5$ in.

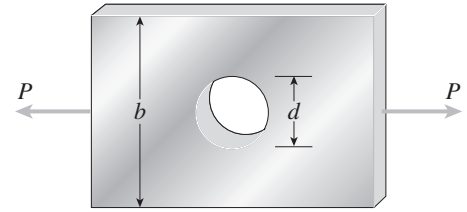

(a)

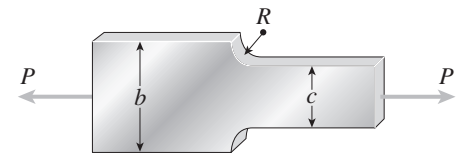

(b)

Probs. 2.10-1 and 2.10-2

Solution 2.10-1 Flat bars in tension

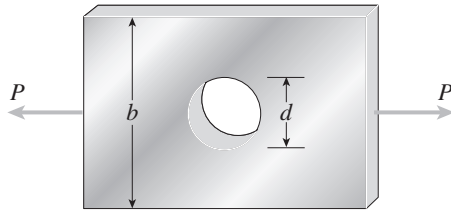

(a)

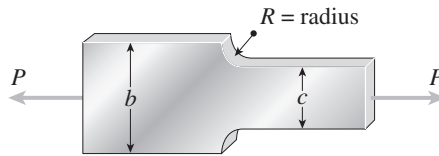

(b)

$$P = 3.0 \text{ k} \quad t = 0.25 \text{ in.}$$

(a) BAR WITH CIRCULAR HOLE ($b = 6$ in.)

Obtain K from Fig. 2-63

FOR $d = 1$ in.: $c = b - d = 5$ in.

$$\sigma_{\text{nom}} = \frac{P}{ct} = \frac{3.0 \text{ k}}{(5 \text{ in.})(0.25 \text{ in.})} = 2.40 \text{ ksi}$$

$$d/b = \frac{1}{6} \quad K \approx 2.60$$

$$\sigma_{\text{max}} = K\sigma_{\text{nom}} \approx 6.2 \text{ ksi} \quad \leftarrow$$

FOR $d = 2$ in.: $c = b - d = 4$ in.

$$\sigma_{\text{nom}} = \frac{P}{ct} = \frac{3.0 \text{ k}}{(4 \text{ in.})(0.25 \text{ in.})} = 3.00 \text{ ksi}$$

$$d/b = \frac{1}{3} \quad K \approx 2.31$$

$$\sigma_{\text{max}} = K\sigma_{\text{nom}} \approx 6.9 \text{ ksi} \quad \leftarrow$$

(b) STEPPED BAR WITH SHOULDER FILLETS

$b = 4.0$ in. $c = 2.5$ in.; Obtain k from Fig. 2-64

$$\sigma_{\text{nom}} = \frac{P}{ct} = \frac{3.0 \text{ k}}{(2.5 \text{ in.})(0.25 \text{ in.})} = 4.80 \text{ ksi}$$

FOR $R = 0.25$ in.: $R/c = 0.1$ $b/c = 1.60$

$$k \approx 2.30 \quad \sigma_{\text{max}} = K\sigma_{\text{nom}} \approx 11.0 \text{ ksi} \quad \leftarrow$$

FOR $R = 0.5$ in.: $R/c = 0.2$ $b/c = 1.60$

$$K \approx 1.87 \quad \sigma_{\text{max}} = K\sigma_{\text{nom}} \approx 9.0 \text{ ksi} \quad \leftarrow$$

Problem 2.10-2 The flat bars shown in parts (a) and (b) of the figure are subjected to tensile forces $P = 2.5$ kN. Each bar has thickness $t = 5.0$ mm.

- (a) For the bar with a circular hole, determine the maximum stresses for hole diameters $d = 12$ mm and $d = 20$ mm if the width $b = 60$ mm.
 (b) For the stepped bar with shoulder fillets, determine the maximum stresses for fillet radii $R = 6$ mm and $R = 10$ mm if the bar widths are $b = 60$ mm and $c = 40$ mm.

Solution 2.10-2 Flat bars in tension

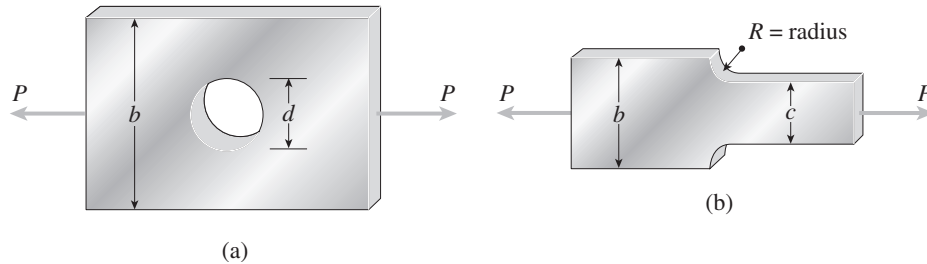

$$P = 2.5 \text{ kN} \quad t = 5.0 \text{ mm}$$

(a) BAR WITH CIRCULAR HOLE ($b = 60$ mm)

Obtain K from Fig. 2-63

FOR $d = 12$ mm: $c = b - d = 48$ mm

$$\sigma_{\text{nom}} = \frac{P}{ct} = \frac{2.5 \text{ kN}}{(48 \text{ mm})(5 \text{ mm})} = 10.42 \text{ MPa}$$

$$d/b = \frac{1}{5} \quad K \approx 2.51$$

$$\sigma_{\text{max}} = K\sigma_{\text{nom}} \approx 26 \text{ MPa} \quad \leftarrow$$

FOR $d = 20$ mm: $c = b - d = 40$ mm

$$\sigma_{\text{nom}} = \frac{P}{ct} = \frac{2.5 \text{ kN}}{(40 \text{ mm})(5 \text{ mm})} = 12.50 \text{ MPa}$$

$$d/b = \frac{1}{3} \quad K \approx 2.31$$

$$\sigma_{\text{max}} = K\sigma_{\text{nom}} \approx 29 \text{ MPa} \quad \leftarrow$$

(b) STEPPED BAR WITH SHOULDER FILLETS

$b = 60$ mm $c = 40$ mm;

Obtain K from Fig. 2-64

$$\sigma_{\text{nom}} = \frac{P}{ct} = \frac{2.5 \text{ kN}}{(40 \text{ mm})(5 \text{ mm})} = 12.50 \text{ MPa}$$

FOR $R = 6$ mm: $R/c = 0.15$ $b/c = 1.5$

$$K \approx 2.00 \quad \sigma_{\text{max}} = K\sigma_{\text{nom}} \approx 25 \text{ MPa} \quad \leftarrow$$

FOR $R = 10$ mm: $R/c = 0.25$ $b/c = 1.5$

$$K \approx 1.75 \quad \sigma_{\text{max}} = K\sigma_{\text{nom}} \approx 22 \text{ MPa} \quad \leftarrow$$

Problem 2.10-3 A flat bar of width b and thickness t has a hole of diameter d drilled through it (see figure). The hole may have any diameter that will fit within the bar.

What is the maximum permissible tensile load P_{\max} if the allowable tensile stress in the material is σ_t ?

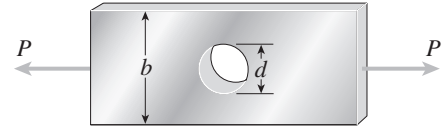

Solution 2.10-3 Flat bar in tension

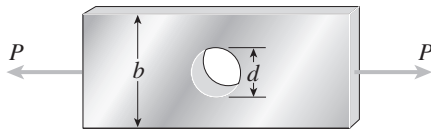

t = thickness

σ_t = allowable tensile stress

Find P_{\max}

Find K from Fig. 2-64

$\frac{d}{b}$	K	P^*
0	3.00	0.333
0.1	2.73	0.330
0.2	2.50	0.320
0.3	2.35	0.298
0.4	2.24	0.268

$$P_{\max} = \sigma_{\text{nom}} ct = \frac{\sigma_{\max}}{K} ct = \frac{\sigma_t}{K} (b - d)t$$

$$= \frac{\sigma_t}{K} bt \left(1 - \frac{d}{b} \right)$$

Because σ_t , b , and t are constants, we write:

$$P^* = \frac{P_{\max}}{\sigma_t bt} = \frac{1}{K} \left(1 - \frac{d}{b} \right)$$

We observe that P_{\max} decreases as d/b increases. Therefore, the maximum load occurs when the hole becomes very small.

$$\left(\frac{d}{b} \rightarrow 0 \text{ and } K \rightarrow 3 \right)$$

$$P_{\max} = \frac{\sigma_t bt}{3} \leftarrow$$

Problem 2.10-4 A round brass bar of diameter $d_1 = 20$ mm has upset ends of diameter $d_2 = 26$ mm (see figure). The lengths of the segments of the bar are $L_1 = 0.3$ m and $L_2 = 0.1$ m. Quarter-circular fillets are used at the shoulders of the bar, and the modulus of elasticity of the brass is $E = 100$ GPa.

If the bar lengthens by 0.12 mm under a tensile load P , what is the maximum stress σ_{\max} in the bar?

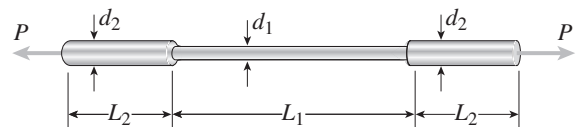

Probs. 2.10-4 and 2.10-5

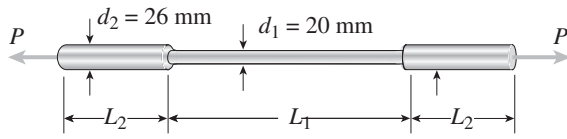
Solution 2.10-4 Round brass bar with upset ends

$$E = 100 \text{ GPa}$$

$$\delta = 0.12 \text{ mm}$$

$$L_2 = 0.1 \text{ m}$$

$$L_1 = 0.3 \text{ m}$$

$$R = \text{radius of fillets} = \frac{26 \text{ mm} - 20 \text{ mm}}{2} = 3 \text{ mm}$$

$$\delta = 2 \left(\frac{PL_2}{EA_2} \right) + \frac{PL_1}{EA_1}$$

$$\text{Solve for } P: P = \frac{\delta EA_1 A_2}{2L_2 A_1 + L_1 A_2}$$

Use Fig. 2-65 for the stress-concentration factor:

$$\begin{aligned} \sigma_{\text{nom}} &= \frac{P}{A_1} = \frac{\delta EA_2}{2L_2 A_1 + L_1 A_2} = \frac{\delta E}{2L_2 \left(\frac{A_1}{A_2} \right) + L_1} \\ &= \frac{\delta E}{2L_2 \left(\frac{d_1}{d_2} \right)^2 + L_1} \end{aligned}$$

SUBSTITUTE NUMERICAL VALUES:

$$\sigma_{\text{nom}} = \frac{(0.12 \text{ mm})(100 \text{ GPa})}{2(0.1 \text{ m}) \left(\frac{20}{26} \right)^2 + 0.3 \text{ m}} = 28.68 \text{ MPa}$$

$$\frac{R}{D_1} = \frac{3 \text{ mm}}{20 \text{ mm}} = 0.15$$

Use the dashed curve in Fig. 2-65. $K \approx 1.6$

$$\begin{aligned} \sigma_{\text{max}} &= K \sigma_{\text{nom}} \approx (1.6)(28.68 \text{ MPa}) \\ &\approx 46 \text{ MPa} \quad \leftarrow \end{aligned}$$

Problem 2.10-5 Solve the preceding problem for a bar of monel metal having the following properties: $d_1 = 1.0$ in., $d_2 = 1.4$ in., $L_1 = 20.0$ in., $L_2 = 5.0$ in., and $E = 25 \times 10^6$ psi. Also, the bar lengthens by 0.0040 in. when the tensile load is applied.

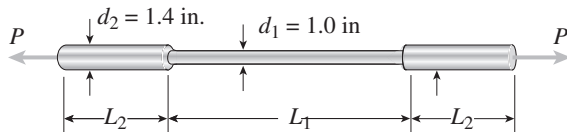
Solution 2.10-5 Round bar with upset ends

$$E = 25 \times 10^6 \text{ psi}$$

$$\delta = 0.0040 \text{ in.}$$

$$L_1 = 20 \text{ in.}$$

$$L_2 = 5 \text{ in.}$$

$$R = \text{radius of fillets} \quad R = \frac{1.4 \text{ in.} - 1.0 \text{ in.}}{2}$$

$$= 0.2 \text{ in.}$$

$$\delta = 2 \left(\frac{PL_2}{EA_2} \right) + \frac{PL_1}{EA_1}$$

$$\text{Solve for } P: P = \frac{\delta EA_1 A_2}{2L_2 A_1 + L_1 A_2}$$

Use Fig. 2-65 for the stress-concentration factor.

$$\begin{aligned} \sigma_{\text{nom}} &= \frac{P}{A_1} = \frac{\delta EA_2}{2L_2 A_1 + L_1 A_2} = \frac{\delta E}{2L_2 \left(\frac{A_1}{A_2} \right) + L_1} \\ &= \frac{\delta E}{2L_2 \left(\frac{d_1}{d_2} \right)^2 + L_1} \end{aligned}$$

SUBSTITUTE NUMERICAL VALUES:

$$\sigma_{\text{nom}} = \frac{(0.0040 \text{ in.})(25 \times 10^6 \text{ psi})}{2(5 \text{ in.}) \left(\frac{1.0}{1.4} \right)^2 + 20 \text{ in.}} = 3,984 \text{ psi}$$

$$\frac{R}{D_1} = \frac{0.2 \text{ in.}}{1.0 \text{ in.}} = 0.2$$

Use the dashed curve in Fig. 2-65. $K \approx 1.53$

$$\begin{aligned} \sigma_{\text{max}} &= K \sigma_{\text{nom}} \approx (1.53)(3,984 \text{ psi}) \\ &\approx 6,100 \text{ psi} \quad \leftarrow \end{aligned}$$

Problem 2.10-6 A prismatic bar of diameter $d_0 = 20$ mm is being compared with a stepped bar of the same diameter ($d_1 = 20$ mm) that is enlarged in the middle region to a diameter $d_2 = 25$ mm (see figure). The radius of the fillets in the stepped bar is 2.0 mm.

- (a) Does enlarging the bar in the middle region make it stronger than the prismatic bar? Demonstrate your answer by determining the maximum permissible load P_1 for the prismatic bar and the maximum permissible load P_2 for the enlarged bar, assuming that the allowable stress for the material is 80 MPa.
- (b) What should be the diameter d_0 of the prismatic bar if it is to have the same maximum permissible load as does the stepped bar?

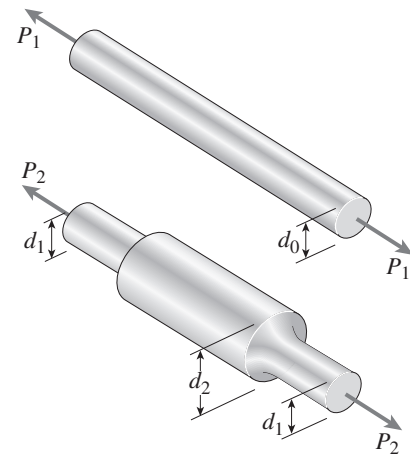

Soluton 2.10-6 Prismatic bar and stepped bar

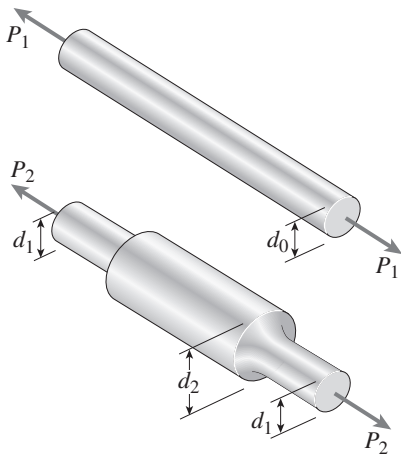

$$d_0 = 20 \text{ mm}$$

$$d_1 = 20 \text{ mm}$$

$$d_2 = 25 \text{ mm}$$

$$\text{Fillet radius: } R = 2 \text{ mm}$$

$$\text{Allowable stress: } \sigma_t = 80 \text{ MPa}$$

(a) COMPARISON OF BARS

$$\text{Prismatic bar: } P_1 = \sigma_t A_0 = \sigma_t \left(\frac{\pi d_0^2}{4} \right)$$

$$= (80 \text{ MPa}) \left(\frac{\pi}{4} \right) (20 \text{ mm})^2 = 25.1 \text{ kN} \quad \leftarrow$$

Stepped bar: See Fig. 2-65 for the stress-concentration factor.

$$R = 2.0 \text{ mm} \quad D_1 = 20 \text{ mm} \quad D_2 = 25 \text{ mm}$$

$$R/D_1 = 0.10 \quad D_2/D_1 = 1.25 \quad K \approx 1.75$$

$$\sigma_{\text{nom}} = \frac{P_2}{\frac{\pi}{4} d_1^2} = \frac{P_2}{A_1} \quad \sigma_{\text{nom}} = \frac{\sigma_{\text{max}}}{K}$$

$$P_2 = \sigma_{\text{nom}} A_1 = \frac{\sigma_{\text{max}}}{K} A_1 = \frac{\sigma_t}{K} A_1$$

$$= \left(\frac{80 \text{ MPa}}{1.75} \right) \left(\frac{\pi}{4} \right) (20 \text{ mm})^2$$

$$\approx 14.4 \text{ kN} \quad \leftarrow$$

Enlarging the bar makes it *weaker*, not stronger. The ratio of loads is $P_1/P_2 = K = 1.75$

(b) DIAMETER OF PRISMATIC BAR FOR THE SAME ALLOWABLE LOAD

$$P_1 = P_2 \quad \sigma_t \left(\frac{\pi d_0^2}{4} \right) = \frac{\sigma_t}{K} \left(\frac{\pi d_1^2}{4} \right) \quad d_0^2 = \frac{d_1^2}{K}$$

$$d_0 = \frac{d_1}{\sqrt{K}} \approx \frac{20 \text{ mm}}{\sqrt{1.75}} \approx 15.1 \text{ mm} \quad \leftarrow$$

Problem 2.10-7 A stepped bar with a hole (see figure) has widths $b = 2.4$ in. and $c = 1.6$ in. The fillets have radii equal to 0.2 in.

What is the diameter d_{\max} of the largest hole that can be drilled through the bar without reducing the load-carrying capacity?

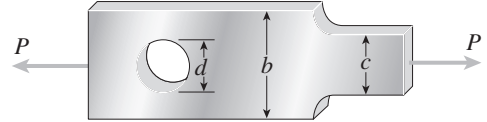

Solution 10-7 Stepped bar with a hole

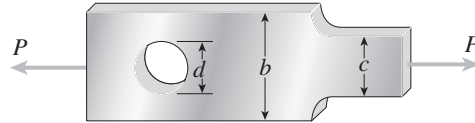

$$b = 2.4 \text{ in.}$$

$$c = 1.6 \text{ in.}$$

$$\text{Fillet radius: } R = 0.2 \text{ in.}$$

Find d_{\max}

BASED UPON FILLETS (Use Fig. 2-64)

$$b = 2.4 \text{ in.} \quad c = 1.6 \text{ in.} \quad R = 0.2 \text{ in.} \quad R/c = 0.125$$

$$b/c = 1.5 \quad K \approx 2.10$$

$$P_{\max} = \sigma_{\text{nom}} ct = \frac{\sigma_{\max}}{K} ct = \frac{\sigma_{\max}}{K} \left(\frac{c}{b}\right)(bt) \\ \approx 0.317 bt \sigma_{\max}$$

BASED UPON HOLE (Use Fig. 2-63)

$$b = 2.4 \text{ in.} \quad d = \text{diameter of the hole (in.)} \quad c_1 = b - d$$

$$P_{\max} = \sigma_{\text{nom}} c_1 t = \frac{\sigma_{\max}}{K} (b - d)t \\ = \frac{1}{K} \left(1 - \frac{d}{b}\right) bt \sigma_{\max}$$

d (in.)	d/b	K	$P_{\max}/bt\sigma_{\max}$
0.3	0.125	2.66	0.329
0.4	0.167	2.57	0.324
0.5	0.208	2.49	0.318
0.6	0.250	2.41	0.311
0.7	0.292	2.37	0.299

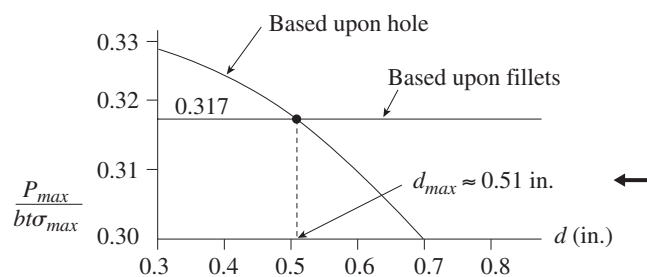

Nonlinear Behavior (Changes in Lengths of Bars)

Problem 2.11-1 A bar AB of length L and weight density γ hangs vertically under its own weight (see figure). The stress-strain relation for the material is given by the Ramberg-Osgood equation (Eq. 2-71):

$$\epsilon = \frac{\sigma}{E} + \frac{\sigma_0 \alpha}{E} \left(\frac{\sigma}{\sigma_0} \right)^m$$

Derive the following formula

$$\delta = \frac{\gamma L^2}{2E} + \frac{\sigma_0 \alpha L}{(m+1)E} \left(\frac{\gamma L}{\sigma_0} \right)^m$$

for the elongation of the bar.

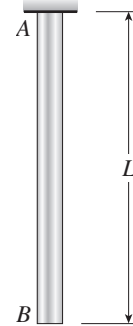

Solution 2.11-1 Bar hanging under its own weight

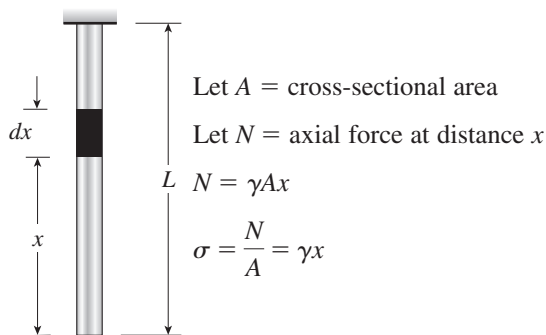

STRAIN AT DISTANCE x

$$\epsilon = \frac{\sigma}{E} + \frac{\sigma_0 \alpha}{E} \left(\frac{\sigma}{\sigma_0} \right)^m = \frac{\gamma x}{E} + \frac{\sigma_0 \alpha}{E} \left(\frac{\gamma x}{\sigma_0} \right)^m$$

ELONGATION OF BAR

$$\begin{aligned} \delta &= \int_0^L \epsilon \, dx = \int_0^L \frac{\gamma x}{E} \, dx + \frac{\sigma_0 \alpha}{E} \int_0^L \left(\frac{\gamma x}{\sigma_0} \right)^m \, dx \\ &= \frac{\gamma L^2}{2E} + \frac{\sigma_0 \alpha L}{(m+1)E} \left(\frac{\gamma L}{\sigma_0} \right)^m \quad \text{Q.E.D.} \quad \leftarrow \end{aligned}$$

Problem 2.11-2 A prismatic bar of length $L = 1.8$ m and cross-sectional area $A = 480$ mm² is loaded by forces $P_1 = 30$ kN and $P_2 = 60$ kN (see figure). The bar is constructed of magnesium alloy having a stress-strain curve described by the following Ramberg-Osgood equation:

$$\epsilon = \frac{\sigma}{45,000} + \frac{1}{618} \left(\frac{\sigma}{170} \right)^{10} \quad (\sigma = \text{MPa})$$

in which σ has units of megapascals.

- Calculate the displacement δ_C of the end of the bar when the load P_1 acts alone.
- Calculate the displacement when the load P_2 acts alone.
- Calculate the displacement when both loads act simultaneously.

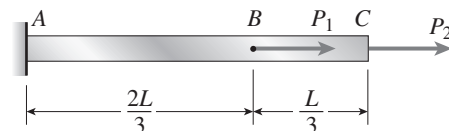

Solution 2.11-2 Axially loaded bar

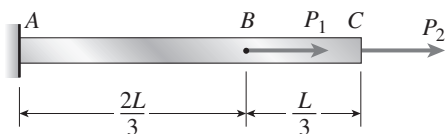

$$L = 1.8 \text{ m} \quad A = 480 \text{ mm}^2$$

$$P_1 = 30 \text{ kN} \quad P_2 = 60 \text{ kN}$$

Ramberg-Osgood Equation:

$$\epsilon = \frac{\sigma}{45,000} + \frac{1}{618} \left(\frac{\sigma}{170} \right)^{10} \quad (\sigma = \text{MPa})$$

Find displacement at end of bar.

(a) P_1 ACTS ALONE

$$AB: \sigma = \frac{P_1}{A} = \frac{30 \text{ kN}}{480 \text{ mm}^2} = 62.5 \text{ MPa}$$

$$\epsilon = 0.001389$$

$$\delta_c = \epsilon \left(\frac{2L}{3} \right) = 1.67 \text{ mm} \quad \leftarrow$$

(b) P_2 ACTS ALONE

$$ABC: \sigma = \frac{P_2}{A} = \frac{60 \text{ kN}}{480 \text{ mm}^2} = 125 \text{ MPa}$$

$$\epsilon = 0.002853$$

$$\delta_c = \epsilon L = 5.13 \text{ mm} \quad \leftarrow$$

(c) BOTH P_1 AND P_2 ARE ACTING

$$AB: \sigma = \frac{P_1 + P_2}{A} = \frac{90 \text{ kN}}{480 \text{ mm}^2} = 187.5 \text{ MPa}$$

$$\epsilon = 0.008477$$

$$\delta_{AB} = \epsilon \left(\frac{2L}{3} \right) = 10.17 \text{ mm}$$

$$BC: \sigma = \frac{P_2}{A} = \frac{60 \text{ kN}}{480 \text{ mm}^2} = 125 \text{ MPa}$$

$$\epsilon = 0.002853$$

$$\delta_{BC} = \epsilon \left(\frac{L}{3} \right) = 1.71 \text{ mm}$$

$$\delta_C = \delta_{AB} + \delta_{BC} = 11.88 \text{ mm} \quad \leftarrow$$

(Note that the displacement when both loads act simultaneously is *not* equal to the sum of the displacements when the loads act separately.)

Problem 2.11-3 A circular bar of length $L = 32$ in. and diameter $d = 0.75$ in. is subjected to tension by forces P (see figure). The wire is made of a copper alloy having the following *hyperbolic stress-strain relationship*:

$$\sigma = \frac{18,000\epsilon}{1 + 300\epsilon} \quad 0 \leq \epsilon \leq 0.03 \quad (\sigma = \text{ksi})$$

(a) Draw a stress-strain diagram for the material.

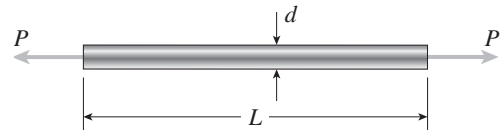
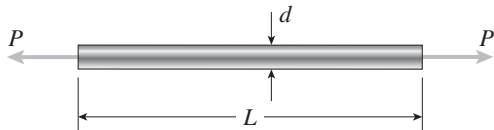
(b) If the elongation of the wire is limited to 0.25 in. and the maximum stress is limited to 40 ksi, what is the allowable load P ?**Solution 2.11-3 Copper bar in tension**

$$L = 32 \text{ in.} \quad d = 0.75 \text{ in.}$$

$$A = \frac{\pi d^2}{4} = 0.4418 \text{ in.}^2$$

(a) STRESS-STRAIN DIAGRAM

$$\sigma = \frac{18,000\epsilon}{1 + 300\epsilon} \quad 0 \leq \epsilon \leq 0.03 \quad (\sigma = \text{ksi})$$

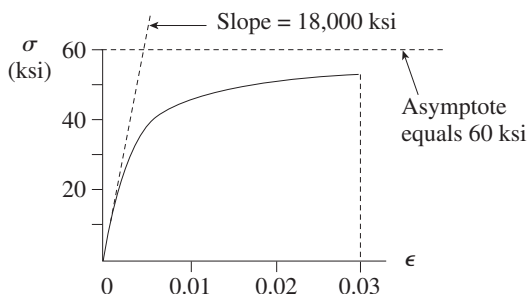
(b) ALLOWABLE LOAD P

$$\text{Max. elongation } \delta_{\max} = 0.25 \text{ in.}$$

$$\text{Max. stress } \sigma_{\max} = 40 \text{ ksi}$$

Based upon elongation:

$$\epsilon_{\max} = \frac{\delta_{\max}}{L} = \frac{0.25 \text{ in.}}{32 \text{ in.}} = 0.007813$$

$$\sigma_{\max} = \frac{18,000 \epsilon_{\max}}{1 + 300 \epsilon_{\max}} = 42.06 \text{ ksi}$$

BASED UPON STRESS:

$$\sigma_{\max} = 40 \text{ ksi}$$

$$\text{Stress governs. } P = \sigma_{\max} A = (40 \text{ ksi})(0.4418 \text{ in.}^2) = 17.7 \text{ k} \quad \leftarrow$$

Problem 2.11-4 A prismatic bar in tension has length $L = 2.0$ m and cross-sectional area $A = 249$ mm². The material of the bar has the stress-strain curve shown in the figure.

Determine the elongation δ of the bar for each of the following axial loads: $P = 10$ kN, 20 kN, 30 kN, 40 kN, and 45 kN. From these results, plot a diagram of load P versus elongation δ (load-displacement diagram).

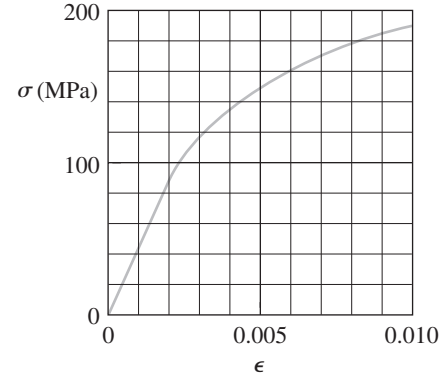

Solution 2.11-4 Bar in tension

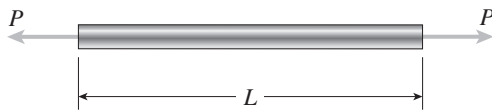

$L = 2.0$ m

$A = 249$ mm²

STRESS-STRAIN DIAGRAM

(See the problem statement for the diagram)

LOAD-DISPLACEMENT DIAGRAM

P (kN)	$\sigma = P/A$ (MPa)	ϵ (from diagram)	$\delta = \epsilon L$ (mm)
10	40	0.0009	1.8
20	80	0.0018	3.6
30	120	0.0031	6.2
40	161	0.0060	12.0
45	181	0.0081	16.2

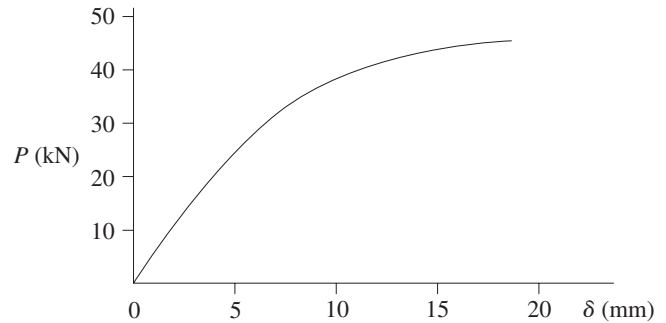

NOTE: The load-displacement curve has the same shape as the stress-strain curve.

Problem 2.11-5 An aluminum bar subjected to tensile forces P has length $L = 150$ in. and cross-sectional area $A = 2.0$ in.² The stress-strain behavior of the aluminum may be represented approximately by the bilinear stress-strain diagram shown in the figure.

Calculate the elongation δ of the bar for each of the following axial loads: $P = 8$ k, 16 k, 24 k, 32 k, and 40 k. From these results, plot a diagram of load P versus elongation δ (load-displacement diagram).

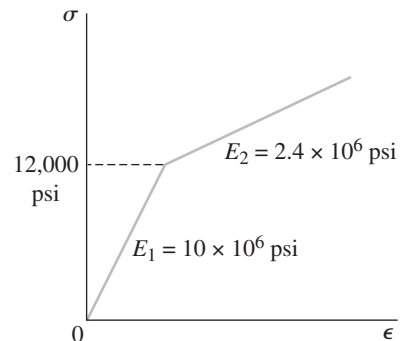

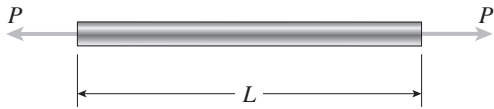
Solution 2.11-5 Aluminum bar in tension

$$L = 150 \text{ in.}$$

$$A = 2.0 \text{ in.}^2$$

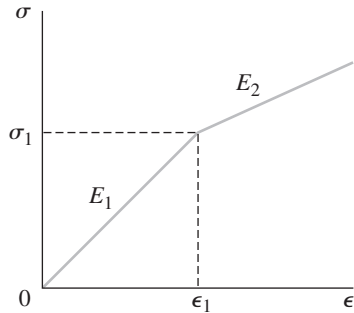
STRESS-STRAIN DIAGRAM

$$E_1 = 10 \times 10^6 \text{ psi}$$

$$E_2 = 2.4 \times 10^6 \text{ psi}$$

$$\sigma_1 = 12,000 \text{ psi}$$

$$\epsilon_1 = \frac{\sigma_1}{E_1} = \frac{12,000 \text{ psi}}{10 \times 10^6 \text{ psi}}$$

$$= 0.0012$$

For $0 \leq \sigma \leq \sigma_1$:

$$\epsilon = \frac{\sigma}{E_1} = \frac{\sigma}{10 \times 10^6 \text{ psi}} \quad (\sigma = \text{psi}) \quad \text{Eq. (1)}$$

For $\sigma \geq \sigma_1$:

$$\begin{aligned} \epsilon &= \epsilon_1 + \frac{\sigma - \sigma_1}{E_2} = 0.0012 + \frac{\sigma - 12,000}{2.4 \times 10^6} \\ &= \frac{\sigma}{2.4 \times 10^6} - 0.0038 \quad (\sigma = \text{psi}) \quad \text{Eq. (2)} \end{aligned}$$

LOAD-DISPLACEMENT DIAGRAM

P (k)	$\sigma = P/A$ (psi)	ϵ (from Eq. 1 or Eq. 2)	$\delta = \epsilon L$ (in.)
8	4,000	0.00040	0.060
16	8,000	0.00080	0.120
24	12,000	0.00120	0.180
32	16,000	0.00287	0.430
40	20,000	0.00453	0.680

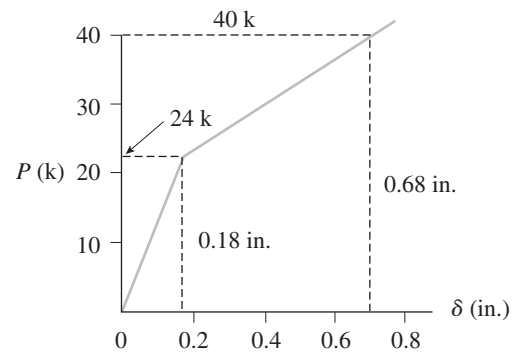

Problem 2.11-6 A rigid bar AB , pinned at end A , is supported by a wire CD and loaded by a force P at end B (see figure). The wire is made of high-strength steel having modulus of elasticity $E = 210$ GPa and yield stress $\sigma_Y = 820$ MPa. The length of the wire is $L = 1.0$ m and its diameter is $d = 3$ mm. The stress-strain diagram for the steel is defined by the *modified power law*, as follows:

$$\sigma = E\epsilon \quad 0 \leq \sigma \leq \sigma_Y$$

$$\sigma = \sigma_Y \left(\frac{E\epsilon}{\sigma_Y} \right)^n \quad \sigma \geq \sigma_Y$$

- (a) Assuming $n = 0.2$, calculate the displacement δ_B at the end of the bar due to the load P . Take values of P from 2.4 kN to 5.6 kN in increments of 0.8 kN.
- (b) Plot a load-displacement diagram showing P versus δ_B .

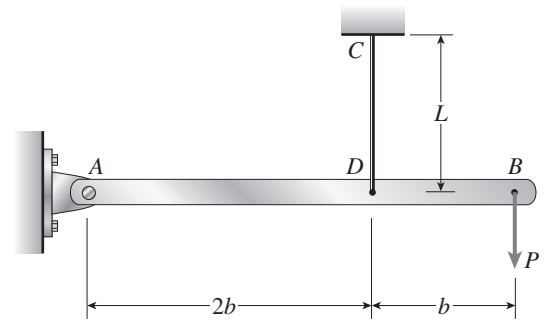

Solution 2.11-6 Rigid bar supported by a wire

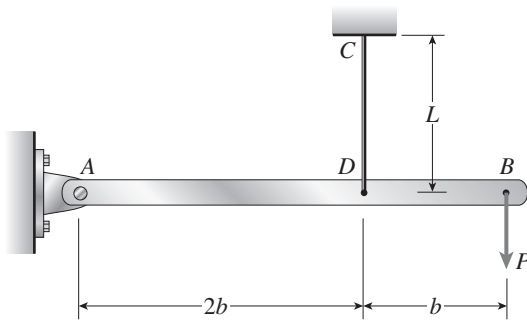

Wire: $E = 210$ GPa

$$\sigma_Y = 820 \text{ MPa}$$

$$L = 1.0 \text{ m}$$

$$d = 3 \text{ mm}$$

$$A = \frac{\pi d^2}{4} = 7.0686 \text{ mm}^2$$

STRESS-STRAIN DIAGRAM

$$\sigma = E\epsilon \quad (0 \leq \sigma \leq \sigma_Y) \tag{1}$$

$$\sigma = \sigma_Y \left(\frac{E\epsilon}{\sigma_Y} \right)^n \quad (\sigma \geq \sigma_Y) \quad (n = 0.2) \tag{2}$$

(a) DISPLACEMENT δ_B AT END OF BAR

$$\delta = \text{elongation of wire} \quad \delta_B = \frac{3}{2} \delta = \frac{3}{2} \epsilon L \tag{3}$$

Obtain ϵ from stress-strain equations:

$$\text{From Eq. (1): } \epsilon = \frac{\sigma}{E} \quad (0 \leq \sigma \leq \sigma_Y) \tag{4}$$

$$\text{From Eq. (2): } \epsilon = \frac{\sigma_Y}{E} \left(\frac{\sigma}{\sigma_Y} \right)^{1/n} \tag{5}$$

$$\text{Axial force in wire: } F = \frac{3P}{2}$$

$$\text{Stress in wire: } \sigma = \frac{F}{A} = \frac{3P}{2A} \tag{6}$$

PROCEDURE: Assume a value of P

Calculate σ from Eq. (6)

Calculate ϵ from Eq. (4) or (5)

Calculate δ_B from Eq. (3)

P (kN)	σ (MPa) Eq. (6)	ϵ Eq. (4) or (5)	δ_B (mm) Eq. (3)
2.4	509.3	0.002425	3.64
3.2	679.1	0.003234	4.85
4.0	848.8	0.004640	6.96
4.8	1018.6	0.01155	17.3
5.6	1188.4	0.02497	37.5

For $\sigma = \sigma_Y = 820$ MPa:

$$\epsilon = 0.0039048 \quad P = 3.864 \text{ kN} \quad \delta_B = 5.86 \text{ mm}$$

(b) LOAD-DISPLACEMENT DIAGRAM

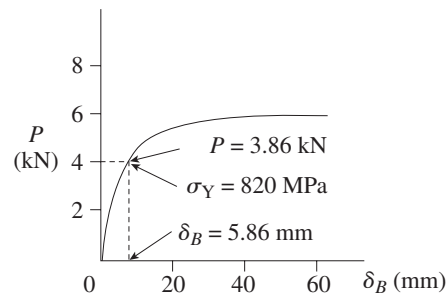

Elastoplastic Analysis

The problems for Section 2.12 are to be solved assuming that the material is elastoplastic with yield stress σ_Y , yield strain ϵ_Y , and modulus of elasticity E in the linearly elastic region (see Fig. 2-70).

Problem 2.12-1 Two identical bars AB and BC support a vertical load P (see figure). The bars are made of steel having a stress-strain curve that may be idealized as elastoplastic with yield stress σ_Y . Each bar has cross-sectional area A .

Determine the yield load P_Y and the plastic load P_p .

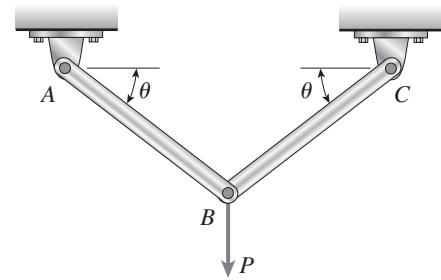

Solution 2.12-1 Two bars supporting a load P

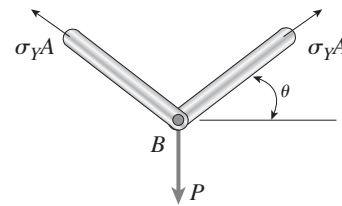
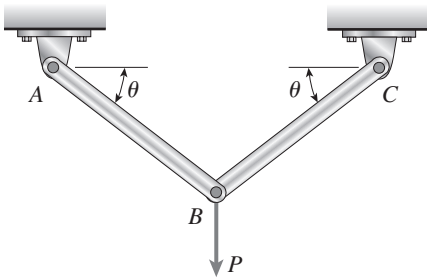

Structure is statically determinate. The yield load P_Y and the plastic load P_p occur at the same time, namely, when both bars reach the yield stress.

JOINT B

$$\Sigma F_{\text{vert}} = 0$$

$$(2\sigma_Y A) \sin \theta = P$$

$$P_Y = P_p = 2\sigma_Y A \sin \theta \quad \leftarrow$$

Problem 2.12-2 A stepped bar ACB with circular cross sections is held between rigid supports and loaded by an axial force P at midlength (see figure). The diameters for the two parts of the bar are $d_1 = 20$ mm and $d_2 = 25$ mm, and the material is elastoplastic with yield stress $\sigma_Y = 250$ MPa.

Determine the plastic load P_p .

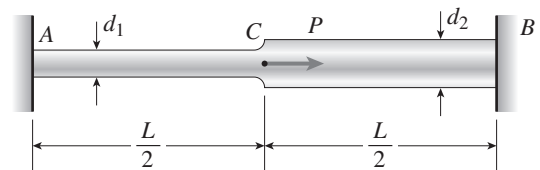

Solution 2.12-2 Bar between rigid supports

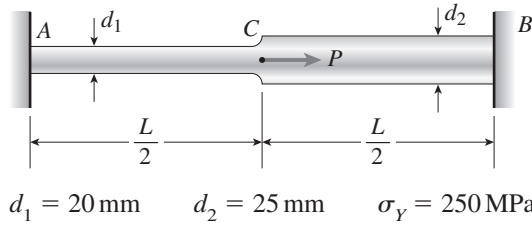

SUBSTITUTE NUMERICAL VALUES:

$$P_p = (250 \text{ MPa}) \left(\frac{\pi}{4} \right) (d_1^2 + d_2^2)$$

$$= (250 \text{ MPa}) \left(\frac{\pi}{4} \right) [(20 \text{ mm})^2 + (25 \text{ mm})^2]$$

$$= 201 \text{ kN} \quad \leftarrow$$

DETERMINE THE PLASTIC LOAD P_p :

At the plastic load, all parts of the bar are stressed to the yield stress.

Point C:

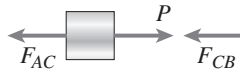

$$F_{AC} = \sigma_Y A_1 \qquad F_{CB} = \sigma_Y A_2$$

$$P = F_{AC} + F_{CB}$$

$$P_p = \sigma_Y A_1 + \sigma_Y A_2 = \sigma_Y (A_1 + A_2) \quad \leftarrow$$

Problem 2.12-3 A horizontal rigid bar AB supporting a load P is hung from five symmetrically placed wires, each of cross-sectional area A (see figure). The wires are fastened to a curved surface of radius R .

- (a) Determine the plastic load P_p if the material of the wires is elastoplastic with yield stress σ_Y .
- (b) How is P_p changed if bar AB is flexible instead of rigid?
- (c) How is P_p changed if the radius R is increased?

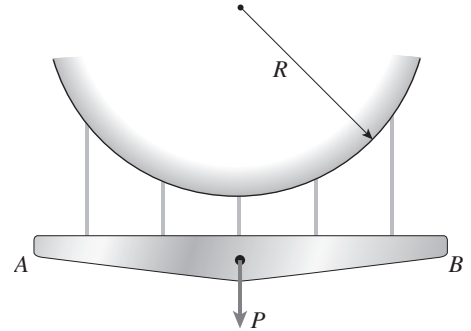

Solution 2.12-3 Rigid bar supported by five wires

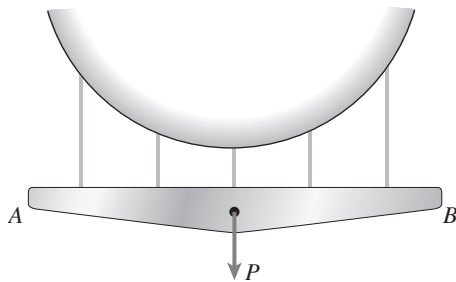

(a) PLASTIC LOAD P_p

At the plastic load, each wire is stressed to the yield stress. $\therefore P_p = 5\sigma_Y A \quad \leftarrow$

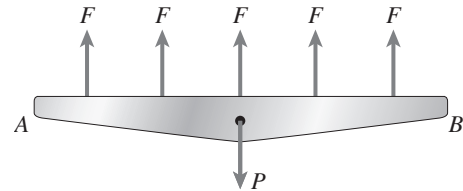

$$F = \sigma_Y A$$

(b) BAR AB IS FLEXIBLE

At the plastic load, each wire is stressed to the yield stress, so the plastic load is not changed. \leftarrow

(c) RADIUS R IS INCREASED

Again, the forces in the wires are not changed, so the plastic load is not changed. \leftarrow

Problem 2.12-4 A load P acts on a horizontal beam that is supported by four rods arranged in the symmetrical pattern shown in the figure. Each rod has cross-sectional area A and the material is elastoplastic with yield stress σ_Y .

Determine the plastic load P_p .

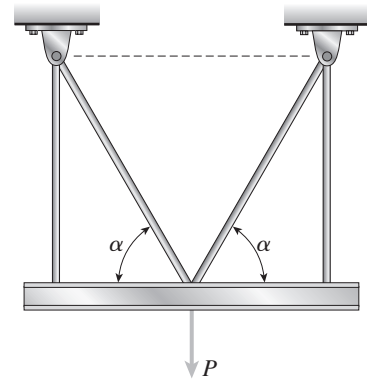

Solution 2.12-4 Beam supported by four rods

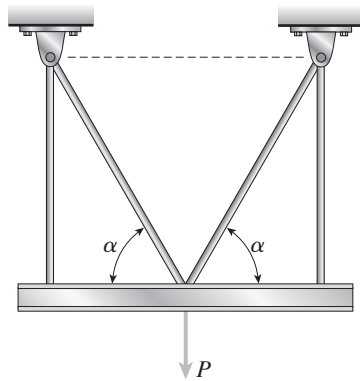

At the plastic load, all four rods are stressed to the yield stress.

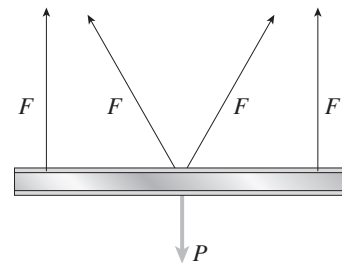

$$F = \sigma_Y A$$

Sum forces in the vertical direction and solve for the load:

$$P_p = 2F + 2F \sin \alpha$$

$$P_p = 2\sigma_Y A (1 + \sin \alpha) \quad \leftarrow$$

Problem 2.12-5 The symmetric truss $ABCDE$ shown in the figure is constructed of four bars and supports a load P at joint E . Each of the two outer bars has a cross-sectional area of 0.307 in.^2 , and each of the two inner bars has an area of 0.601 in.^2 . The material is elastoplastic with yield stress $\sigma_Y = 36 \text{ ksi}$.

Determine the plastic load P_p .

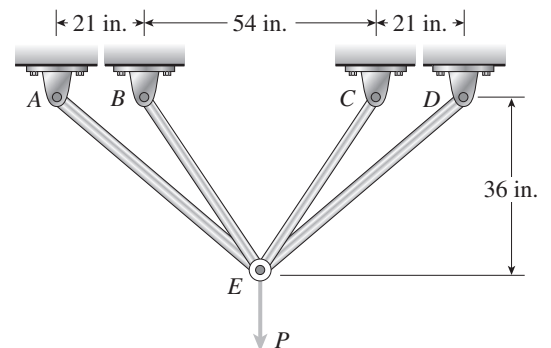

Solution 2.12-5 Truss with four bars

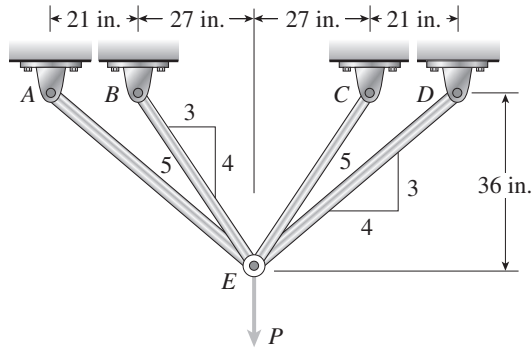

$L_{AE} = 60 \text{ in.}$ $L_{BE} = 45 \text{ in.}$

JOINT E

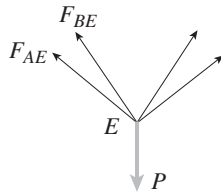

Equilibrium:

$$2F_{AE} \left(\frac{3}{5} \right) + 2F_{BE} \left(\frac{4}{5} \right) = P$$

or

$$P = \frac{6}{5} F_{AE} + \frac{8}{5} F_{BE}$$

PLASTIC LOAD P_p

At the plastic load, all bars are stressed to the yield stress.

$$F_{AE} = \sigma_Y A_{AE} \qquad F_{BE} = \sigma_Y A_{BE}$$

$$P_p = \frac{6}{5} \sigma_Y A_{AE} + \frac{8}{5} \sigma_Y A_{BE} \quad \leftarrow$$

SUBSTITUTE NUMERICAL VALUES:

$$A_{AE} = 0.307 \text{ in.}^2 \quad A_{BE} = 0.601 \text{ in.}^2$$

$$\sigma_Y = 36 \text{ ksi}$$

$$P_p = \frac{6}{5} (36 \text{ ksi})(0.307 \text{ in.}^2) + \frac{8}{5} (36 \text{ ksi})(0.601 \text{ in.}^2)$$

$$= 13.26 \text{ k} + 34.62 \text{ k} = 47.9 \text{ k} \quad \leftarrow$$

Problem 2.12-6 Five bars, each having a diameter of 10 mm, support a load P as shown in the figure. Determine the plastic load P_p if the material is elastoplastic with yield stress $\sigma_Y = 250 \text{ MPa}$.

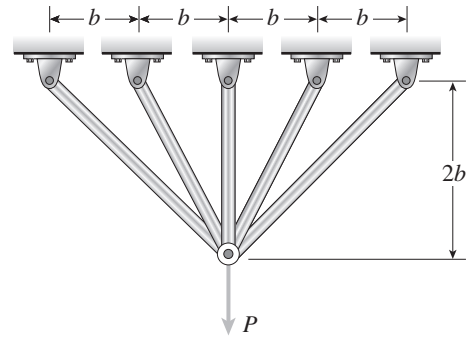

Solution 2.12-6 Truss consisting of five bars

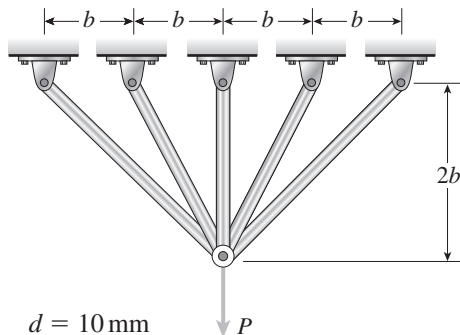

$d = 10 \text{ mm}$

$$A = \frac{\pi d^2}{4} = 78.54 \text{ mm}^2$$

$\sigma_Y = 250 \text{ MPa}$

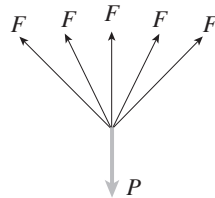

At the plastic load, all five bars are stressed to the yield stress

$$F = \sigma_Y A$$

Sum forces in the vertical direction and solve for the load:

$$P_p = 2F \left(\frac{1}{\sqrt{2}} \right) + 2F \left(\frac{2}{\sqrt{5}} \right) + F$$

$$= \frac{\sigma_Y A}{5} (5\sqrt{2} + 4\sqrt{5} + 5)$$

$$= 4.2031 \sigma_Y A \quad \leftarrow$$

Substitute numerical values:

$$P_p = (4.2031)(250 \text{ MPa})(78.54 \text{ mm}^2)$$

$$= 82.5 \text{ kN} \quad \leftarrow$$

Problem 2.12-7 A circular steel rod AB of diameter $d = 0.60$ in. is stretched tightly between two supports so that initially the tensile stress in the rod is 10 ksi (see figure). An axial force P is then applied to the rod at an intermediate location C .

- Determine the plastic load P_p if the material is elastoplastic with yield stress $\sigma_y = 36$ ksi.
- How is P_p changed if the initial tensile stress is doubled to 20 ksi?

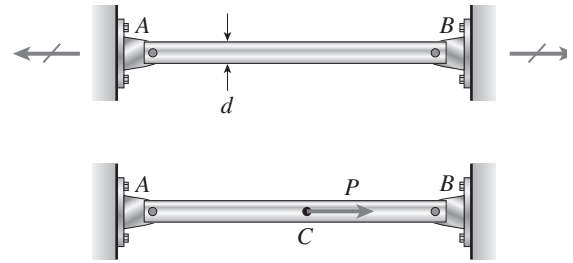

Solution 2.12-7 Bar held between rigid supports

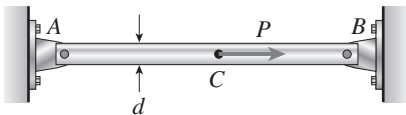

$$d = 0.60 \text{ in.}$$

$$\sigma_y = 36 \text{ ksi}$$

$$\text{Initial tensile stress} = 10 \text{ ksi}$$

- (a) PLASTIC LOAD P_p

The presence of the initial tensile stress does not affect the plastic load. Both parts of the bar must yield in order to reach the plastic load.

POINT C:



$$P_p = 2\sigma_y A = (2)(36 \text{ ksi}) \left(\frac{\pi}{4} \right) (0.60 \text{ in.})^2$$

$$= 20.4 \text{ k} \quad \leftarrow$$

- (B) INITIAL TENSILE STRESS IS DOUBLED

P_p is not changed. \leftarrow

Problem 2.12-8 A rigid bar ACB is supported on a fulcrum at C and loaded by a force P at end B (see figure). Three identical wires made of an elastoplastic material (yield stress σ_y and modulus of elasticity E) resist the load P . Each wire has cross-sectional area A and length L .

- Determine the yield load P_y and the corresponding yield displacement δ_y at point B .
- Determine the plastic load P_p and the corresponding displacement δ_p at point B when the load just reaches the value P_p .
- Draw a load-displacement diagram with the load P as ordinate and the displacement δ_B of point B as abscissa.

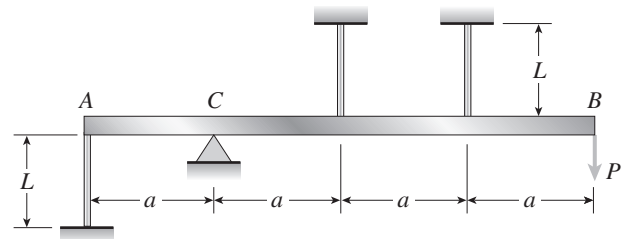

Solution 2.12-8 Rigid bar supported by wires

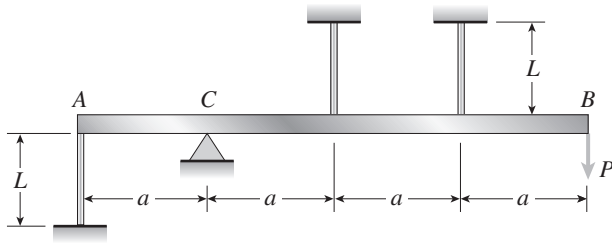

(a) YIELD LOAD P_Y

Yielding occurs when the most highly stressed wire reaches the yield stress σ_Y .

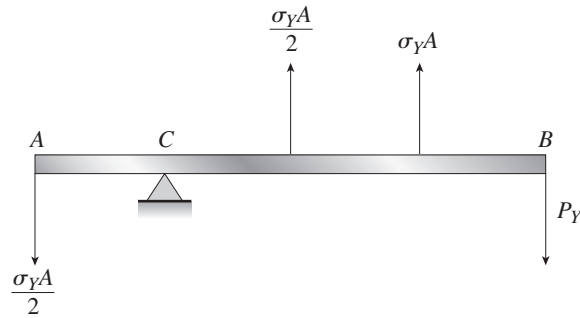

$$\sum M_C = 0$$

$$P_Y = \sigma_Y A \quad \leftarrow$$

At point A:

$$\delta_A = \left(\frac{\sigma_Y A}{2}\right)\left(\frac{L}{EA}\right) = \frac{\sigma_Y L}{2E}$$

At point B:

$$\delta_B = 3\delta_A = \delta_Y = \frac{3\sigma_Y L}{2E} \quad \leftarrow$$

(b) PLASTIC LOAD P_P

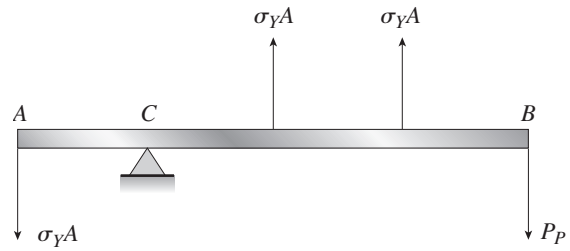

At the plastic load, all wires reach the yield stress.

$$\sum M_C = 0$$

$$P_P = \frac{4\sigma_Y A}{3} \quad \leftarrow$$

At point A:

$$\delta_A = (\sigma_Y A)\left(\frac{L}{EA}\right) = \frac{\sigma_Y L}{E}$$

At point B:

$$\delta_B = 3\delta_A = \delta_P = \frac{3\sigma_Y L}{E} \quad \leftarrow$$

(c) LOAD-DISPLACEMENT DIAGRAM

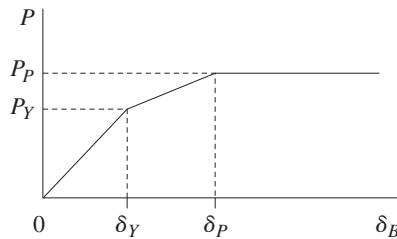

$$P_P = \frac{4}{3} P_Y$$

$$\delta_P = 2\delta_Y$$

Problem 2.12-9 The structure shown in the figure consists of a horizontal rigid bar $ABCD$ supported by two steel wires, one of length L and the other of length $3L/4$. Both wires have cross-sectional area A and are made of elastoplastic material with yield stress σ_Y and modulus of elasticity E . A vertical load P acts at end D of the bar.

- Determine the yield load P_Y and the corresponding yield displacement δ_Y at point D .
- Determine the plastic load P_P and the corresponding displacement δ_P at point D when the load just reaches the value P_P .
- Draw a load-displacement diagram with the load P as ordinate and the displacement δ_D of point D as abscissa.

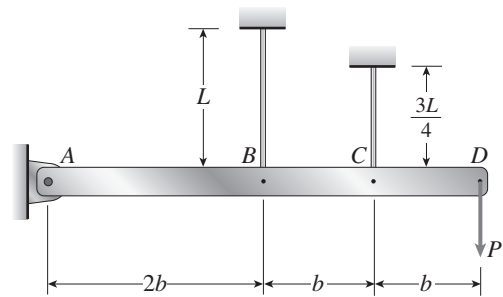

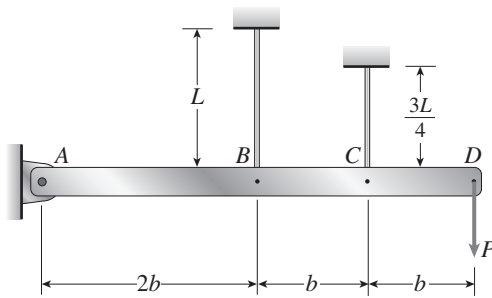
Solution 2.12-9 Rigid bar supported by two wires

A = cross-sectional area
 σ_Y = yield stress
 E = modulus of elasticity

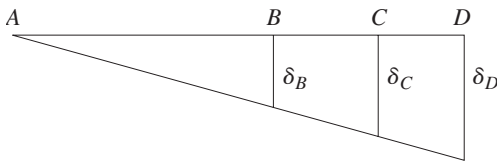
DISPLACEMENT DIAGRAM**COMPATIBILITY:**

$$\delta_C = \frac{3}{2} \delta_B$$

$$\delta_D = 2\delta_B$$

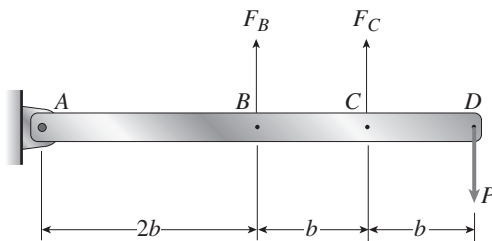
FREE-BODY DIAGRAM**EQUILIBRIUM:**

$$\begin{aligned} \Sigma M_A = 0 \quad \curvearrowright \quad F_B(2b) + F_C(3b) &= P(4b) \\ 2F_B + 3F_C &= 4P \end{aligned} \quad (3)$$

FORCE-DISPLACEMENT RELATIONS

$$\delta_B = \frac{F_B L}{EA} \quad \delta_C = \frac{F_C \left(\frac{3}{4}L\right)}{EA} \quad (4, 5)$$

Substitute into Eq. (1):

$$\begin{aligned} \frac{3F_C L}{4EA} &= \frac{3F_B L}{2EA} \\ F_C &= 2F_B \end{aligned}$$

STRESSES

$$\sigma_B = \frac{F_B}{A} \quad \sigma_C = \frac{F_C}{A} \quad \therefore \sigma_C = 2\sigma_B \quad (7)$$

Wire C has the larger stress. Therefore, it will yield first.

(a) YIELD LOAD

$$\sigma_C = \sigma_Y \quad \sigma_B = \frac{\sigma_C}{2} = \frac{\sigma_Y}{2} \quad (\text{From Eq. 7})$$

$$F_C = \sigma_Y A \quad F_B = \frac{1}{2} \sigma_Y A$$

From Eq. (3):

$$2\left(\frac{1}{2}\sigma_Y A\right) + 3(\sigma_Y A) = 4P$$

$$P = P_Y = \sigma_Y A \quad \leftarrow$$

From Eq. (4):

$$\delta_B = \frac{F_B L}{EA} = \frac{\sigma_Y L}{2E}$$

From Eq. (2):

$$\delta_D = \delta_Y = 2\delta_B = \frac{\sigma_Y L}{E} \quad \leftarrow$$

(b) PLASTIC LOAD

At the plastic load, both wires yield.

$$\sigma_B = \sigma_Y = \sigma_C \quad F_B = F_C = \sigma_Y A$$

From Eq. (3):

$$2(\sigma_Y A) + 3(\sigma_Y A) = 4P$$

$$P = P_P = \frac{5}{4} \sigma_Y A \quad \leftarrow$$

From Eq. (4):

$$\delta_B = \frac{F_B L}{EA} = \frac{\sigma_Y L}{E}$$

From Eq. (2):

$$\delta_D = \delta_P = 2\delta_B = \frac{2\sigma_Y L}{E} \quad \leftarrow$$

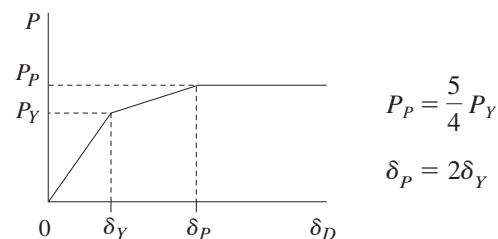
(c) LOAD-DISPLACEMENT DIAGRAM

(6)

Problem 2.12-10 Two cables, each having a length L of approximately 40 m, support a loaded container of weight W (see figure). The cables, which have effective cross-sectional area $A = 48.0 \text{ mm}^2$ and effective modulus of elasticity $E = 160 \text{ GPa}$, are identical except that one cable is longer than the other when they are hanging separately and unloaded. The difference in lengths is $d = 100 \text{ mm}$. The cables are made of steel having an elastoplastic stress-strain diagram with $\sigma_Y = 500 \text{ MPa}$. Assume that the weight W is initially zero and is slowly increased by the addition of material to the container.

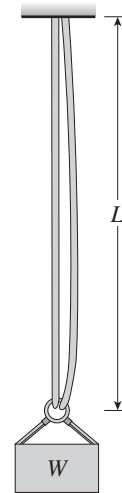

- Determine the weight W_Y that first produces yielding of the shorter cable. Also, determine the corresponding elongation δ_Y of the shorter cable.
- Determine the weight W_P that produces yielding of both cables. Also, determine the elongation δ_P of the shorter cable when the weight W just reaches the value W_P .
- Construct a load-displacement diagram showing the weight W as ordinate and the elongation δ of the shorter cable as abscissa. (*Hint:* The load displacement diagram is not a single straight line in the region $0 \leq W \leq W_Y$.)

Solution 2.12-10 Two cables supporting a load

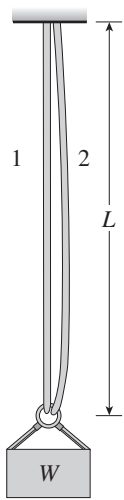

$$L = 40 \text{ m} \quad A = 48.0 \text{ mm}^2$$

$$E = 160 \text{ GPa}$$

$$d = \text{difference in length} = 100 \text{ mm}$$

$$\sigma_Y = 500 \text{ MPa}$$

INITIAL STRETCHING OF CABLE 1

Initially, cable 1 supports all of the load.

Let $W_1 =$ load required to stretch cable 1 to the same length as cable 2

$$W_1 = \frac{EA}{L}d = 19.2 \text{ kN}$$

$$\delta_1 = 100 \text{ mm (elongation of cable 1)}$$

$$\sigma_1 = \frac{W_1}{A} = \frac{Ed}{L} = 400 \text{ MPa} \quad (\sigma_1 < \sigma_Y \therefore \text{OK})$$

(a) YIELD LOAD W_Y

Cable 1 yields first. $F_1 = \sigma_Y A = 24 \text{ kN}$

$\delta_{1Y} =$ total elongation of cable 1

$$\delta_{1Y} = \frac{F_1 L}{EA} = \frac{\sigma_Y L}{E} = 0.125 \text{ m} = 125 \text{ mm}$$

$$\delta_Y = \delta_{1Y} = 125 \text{ mm} \quad \leftarrow$$

$\delta_{2Y} =$ elongation of cable 2

$$= \delta_{1Y} - d = 25 \text{ mm}$$

$$F_2 = \frac{EA}{L} \delta_{2Y} = 4.8 \text{ kN}$$

$$W_Y = F_1 + F_2 = 24 \text{ kN} + 4.8 \text{ kN}$$

$$= 28.8 \text{ kN} \quad \leftarrow$$

(b) PLASTIC LOAD W_P

$$F_1 = \sigma_Y A \quad F_2 = \sigma_Y A$$

$$W_P = 2\sigma_Y A = 48 \text{ kN} \quad \leftarrow$$

$\delta_{2P} =$ elongation of cable 2

$$= F_2 \left(\frac{L}{EA} \right) = \frac{\sigma_Y L}{E} = 0.125 \text{ m} = 125 \text{ mm}$$

$$\delta_{1P} = \delta_{2P} + d = 225 \text{ mm}$$

$$\delta_P = \delta_{1P} = 225 \text{ mm} \quad \leftarrow$$

(c) LOAD-DISPLACEMENT DIAGRAM

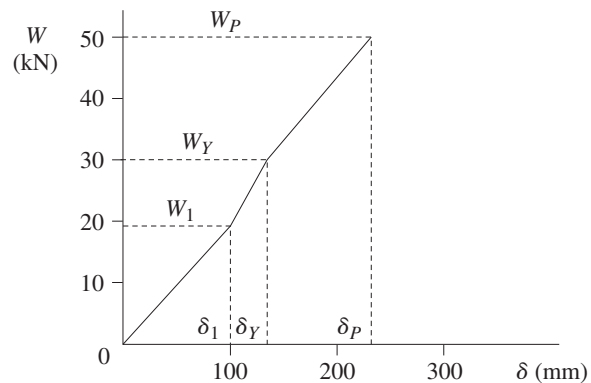

$$\frac{W_Y}{W_1} = 1.5 \quad \frac{\delta_Y}{\delta_1} = 1.25$$

$$\frac{W_P}{W_Y} = 1.667 \quad \frac{\delta_P}{\delta_Y} = 1.8$$

$$0 < W < W_1: \text{slope} = 192,000 \text{ N/m}$$

$$W_1 < W < W_Y: \text{slope} = 384,000 \text{ N/m}$$

$$W_Y < W < W_P: \text{slope} = 192,000 \text{ N/m}$$

Problem 2.12-11 A hollow circular tube T of length $L = 15$ in. is uniformly compressed by a force P acting through a rigid plate (see figure). The outside and inside diameters of the tube are 3.0 and 2.75 in., respectively. A concentric solid circular bar B of 1.5 in. diameter is mounted inside the tube. When no load is present, there is a clearance $c = 0.010$ in. between the bar B and the rigid plate. Both bar and tube are made of steel having an elastoplastic stress-strain diagram with $E = 29 \times 10^3$ ksi and $\sigma_Y = 36$ ksi.

- Determine the yield load P_Y and the corresponding shortening δ_Y of the tube.
- Determine the plastic load P_p and the corresponding shortening δ_p of the tube.
- Construct a load-displacement diagram showing the load P as ordinate and the shortening δ of the tube as abscissa.
(Hint: The load-displacement diagram is not a single straight line in the region $0 \leq P \leq P_Y$.)

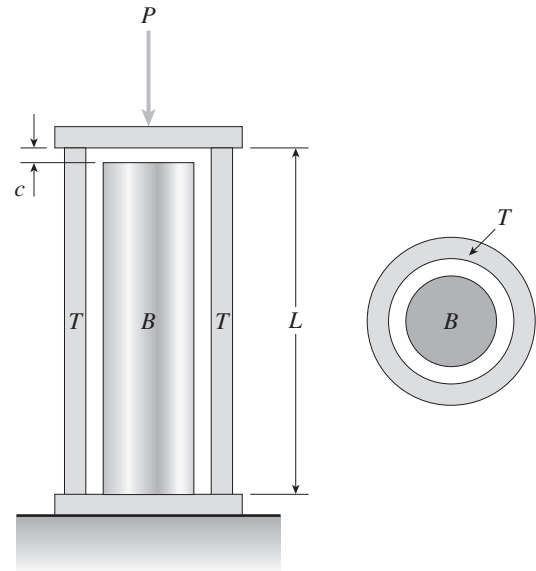

Solution 2.12-11 Tube and bar supporting a load

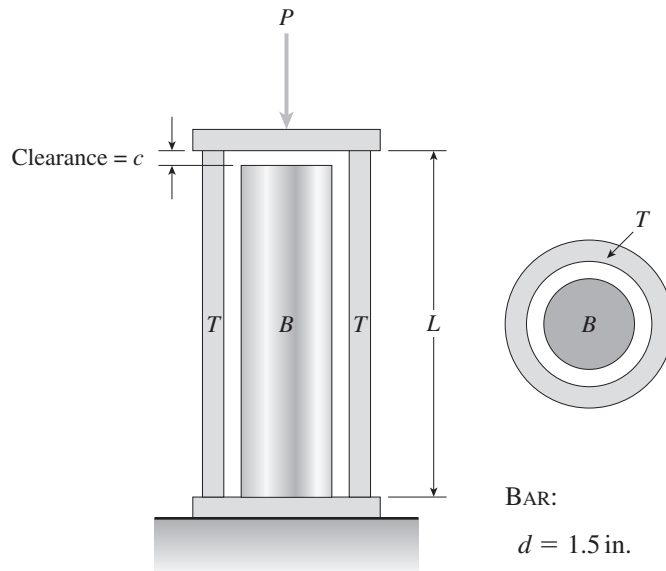

$$L = 15 \text{ in.}$$

$$c = 0.010 \text{ in.}$$

$$E = 29 \times 10^3 \text{ ksi}$$

$$\sigma_Y = 36 \text{ ksi}$$

TUBE:

$$d_2 = 3.0 \text{ in.}$$

$$d_1 = 2.75 \text{ in.}$$

$$A_T = \frac{\pi}{4}(d_2^2 - d_1^2) = 1.1290 \text{ in.}^2$$

BAR:

$$d = 1.5 \text{ in.}$$

$$A_B = \frac{\pi d^2}{4} = 1.7671 \text{ in.}^2$$

INITIAL SHORTENING OF TUBE T

Initially, the tube supports all of the load.

Let P_1 = load required to close the clearance

$$P_1 = \frac{EA_T}{L} c = 21,827 \text{ lb}$$

Let δ_1 = shortening of tube $\delta_1 = c = 0.010$ in.

$$\sigma_1 = \frac{P_1}{A_T} = 19,330 \text{ psi} \quad (\sigma_1 < \sigma_Y \therefore \text{OK})$$

(Continued)

(a) YIELD LOAD P_Y

Because the tube and bar are made of the same material, and because the strain in the tube is larger than the strain in the bar, the tube will yield first.

$$F_T = \sigma_Y A_T = 40,644 \text{ lb}$$

δ_{TY} = shortening of tube at the yield stress

$$\delta_{TY} = \frac{F_T L}{EA_T} = \frac{\sigma_Y L}{E} = 0.018621 \text{ in.}$$

$$\delta_Y = \delta_{TY} = 0.01862 \text{ in.} \quad \leftarrow$$

δ_{BY} = shortening of bar

$$= \delta_{TY} - c = 0.008621 \text{ in.}$$

$$F_B = \frac{EA_B}{L} \delta_{BY} = 29,453 \text{ lb}$$

$$P_Y = F_T + F_B = 40,644 \text{ lb} + 29,453 \text{ lb} \\ = 70,097 \text{ lb}$$

$$P_Y = 70,100 \text{ lb} \quad \leftarrow$$

(b) PLASTIC LOAD P_P

$$F_T = \sigma_Y A_T \quad F_B = \sigma_Y A_B$$

$$P_P = F_T + F_B = \sigma_Y (A_T + A_B) \\ = 104,300 \text{ lb} \quad \leftarrow$$

δ_{BP} = shortening of bar

$$= F_B \left(\frac{L}{EA_B} \right) = \frac{\sigma_Y L}{E} = 0.018621 \text{ in.}$$

$$\delta_{TP} = \delta_{BP} + c = 0.028621 \text{ in.}$$

$$\delta_P = \delta_{TP} = 0.02862 \text{ in.} \quad \leftarrow$$

(c) LOAD-DISPLACEMENT DIAGRAM

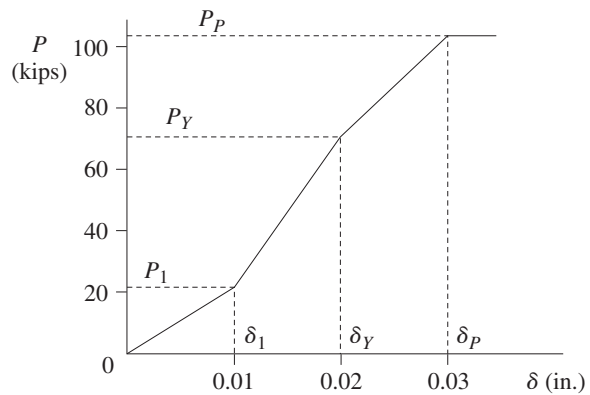

$$\frac{P_Y}{P_1} = 3.21 \quad \frac{\delta_Y}{\delta_1} = 1.86$$

$$\frac{P_P}{P_Y} = 1.49 \quad \frac{\delta_P}{\delta_Y} = 1.54$$

$$0 < P < P_1: \quad \text{slope} = 2180 \text{ k/in.}$$

$$P_1 < P < P_Y: \quad \text{slope} = 5600 \text{ k/in.}$$

$$P_Y < P < P_P: \quad \text{slope} = 3420 \text{ k/in.}$$